

Keyflex Australia

U4, 15 Rosslyn Street
West Leederville 6007 Australia
Telephone +618 9388 7366
Email sales@keyflex.com.au
Web: www.keyflex.com.au

Keyflex Hong Kong

502 Golden Gate Commercial Bld
136-138 Austin Road, Kowloon, HK
Telephone: +852 8120 7299
Email info@keyflex.com.hk
Web: www.keyflex.com.hk

T E C H N I C A L I N F O R M A T I O N

Silicon Keypads offer highly reliable and versatile solutions to the many assembly and environmental problems that arise in electronics manufacturing.

With their ease of assembly as one complete keypad, production costs can be greatly reduced in comparison with board mount switches, whilst maintaining tactile feel and switch travel.

As many applications require sealing against the effects of dust and moisture, this can prove difficult when utilising conventional switches with overlays. Silicon keypads are ideally suited to this role with the ability to be compressed between the board and the moulding, creating a seal. For added protection the keypad can be designed to wrap around the edges of the circuit board, providing a sealed enclosure for all critical components inside.

Being rubber based, the keypads display excellent stability across a wide temperature range, without the problems associated with adhesives often used with seals for board mount switches.

Rubber's resistance to numerous chemicals is far superior to that of the polycarbonates etc. used for graphic overlays, making it suitable for use in harsh environments. Aesthetically, silicon keypads can be designed to meet the expected high standards that society demands, especially when dealing in the expanding overseas markets.

The moulding process allows almost any key shape to be achieved, complemented by the use of any Pantone colour desired, both in the key structure and the printed detail. For applications requiring backlighting, Translucent silicon is used, ensuring an even spread of light throughout the keypad.

Should you prefer to have a Plastic keycap, these too can be provided in a range of colours and shapes, with the key information either being printed on the keycap or engraved into the plastic. For versatility, the keycaps can be supplied clear, allowing the user to fit any form of labelling underneath the clear cap, which of course can then be changed at any time.

Actuation force and tactile feedback can be designed to meet a range of applications, where the "feel" of the key is of importance to the everyday user.

Following are some general specifications and design information. Should you require some assistance with design or further technical information, please contact us using the below details

15 Rosslyn Street,
West Leederville 6007
Telephone: +618 9388 7366
sales@keyflex.com.au
www.keyflex.com.au

GENERAL SPECIFICATIONS

Operating Temperature:	-15 C to 80 C
Storage Temperature:	-30 C to 70 C
Operating Force:	50 to 350 grams
Cycle Life:	300,000 to 30 million
Contact Resistance:	<100 ohms
Contact Rating:	5mA@12VDC
Contact Bounce:	<12 milliseconds
Insulation	¹²
Resistance: Break	> 10 ¹² ohms @ 500VDC
Voltage:	>25-30KV/
Key Colour:	Optional
Key Size:	Optional
Key Shape:	Optional
Tactile Feedback:	Optional
Print Colour:	Optional

Conductive Rubber

Specific Gravity:	1.06 - 1.18
Hardness Shore A:	60 - 65
Tensile Strength kg/cm:	65
Elongation %:	300
Compression Set %:	15 - 25
Volume resistivity ohm-cm	4

Insulative Rubber

Specific Gravity:	1.10 - 1.40
Hardness Shore A:	35 - 80
Tensile Strength kg/cm:	50 - 80
Elongation %:	400
Compression Set %:	18 - 20
Volume resistivity ohm-cm	
Room Temperature	2×10^{14}
After 24 Hours @ 150 C	3×20^{14}

Standard Conductive PIL sizes:

Diameter (mm)	2.0	2.5	3.0	3.5	4.0	4.5	5.0	5.5	6.0
Thickness (mm)	0.8	0.8	0.8	0.8	1.0	1.0	1.0	1.0	1.0

Please note that the Conductive PILs can be produced to almost any design, including PILs with the centre removed for backlighting using a LED mounted under the switch centre.

D I M E N S I O N A L G U I D E L I N E S

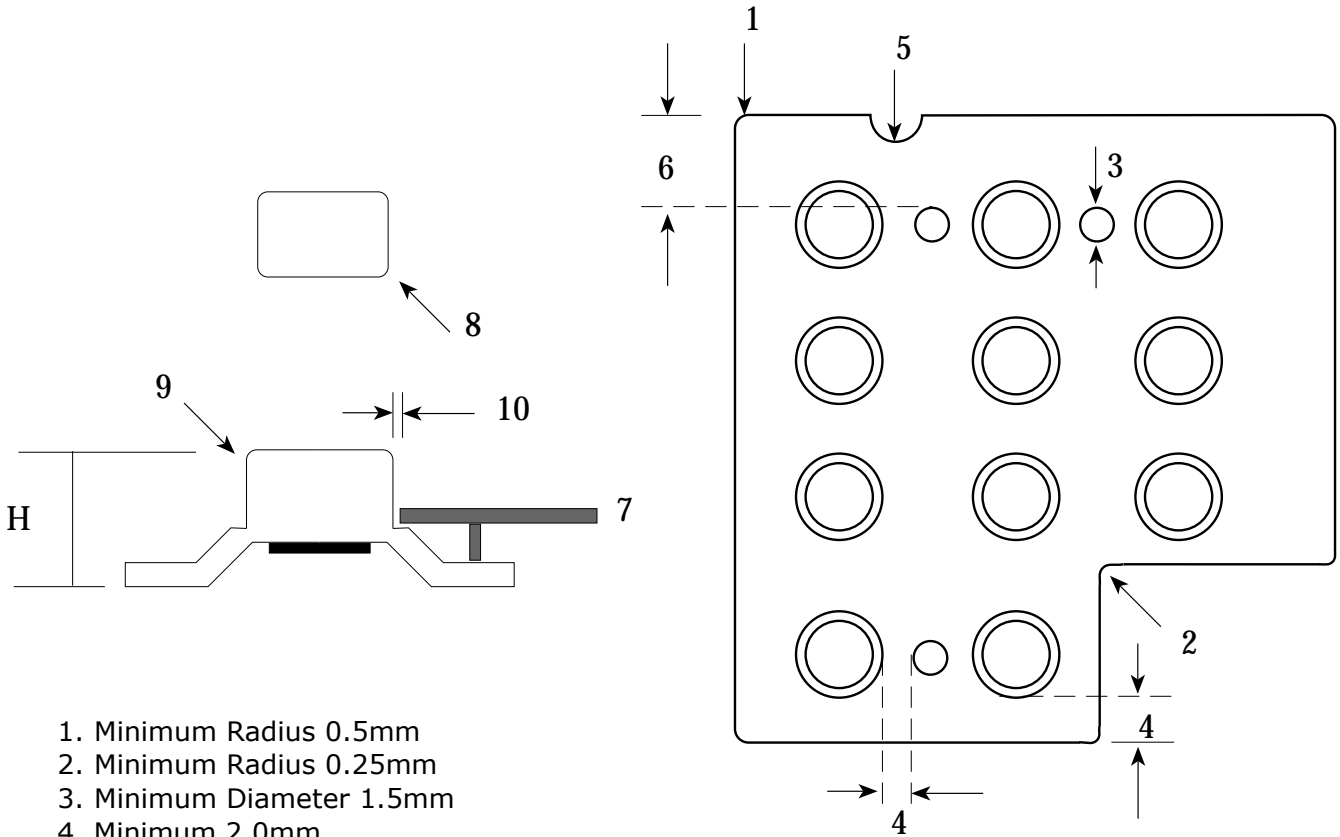

- 1. Minimum Radius 0.5mm
- 2. Minimum Radius 0.25mm
- 3. Minimum Diameter 1.5mm
- 4. Minimum 2.0mm
- 5. Minimum Radius 0.5mm
- 6. Minimum 3.0mm
- 7. Plastic Moulding
- 8. If $H < 7\text{mm}$, minimum Radius 0.5mm
If $H > 7\text{mm} < 10\text{mm}$, minimum Radius 0.9mm
- 9. Minimum 0.2mm
- 10. Typical 0.15mm

Typical Tolerances (mm)

Dimension	L < 10	L >10, < 20	L >20, < 30	L >30, < 50	L >50, < 100	L >100
Tolerance						
Normal	+/-0.1	+/-0.15	+/-0.20	+/-0.25	+/-0.50	+/- 1.0%
Critical	+/-0.05	+/-0.08	+/-0.10	+/-0.15	+/- 0.3%	+/- 0.5%

Typical Application Specifications

Appliance:	Key Travel (mm):	Actuation Force (gms):	Operating Life:
Audio Equipment	0.3-0.	90-150	100,000
Car Radio	0.3-0.	150-250	300,000
Computer Keyboard	2.5-3.	50-90	10 million
Remote Control	0.3-1.	90-150	500,000
Telephone	2.0-4.	150-250	1 million
Video	1.0-1.	100-200	500,000

FORCE SPECIFICATION RECOMMENDATION

* Actuation Force:

50 grams ± 5 - ± 10	70 grams ± 10 - ± 15
90 grams ± 15 - ± 20	100 grams ± 15 - ± 20
120 grams ± 20 - ± 25	150 grams ± 20 - ± 25
170 grams ± 25 - ± 30	200 grams - 350 grams ± 35

* Snap Ratio 0.4 ~ 0.6 (Tactile Type)
 0.2 ~ 0.3 (Non Tactile)

* Minimum Return 20gm or 25gm

* Travel Minimum 1.0mm (Tactile)
 Minimum 0.5mm (Non Tactile)

ELECTRODE PATTERN EXAMPLES

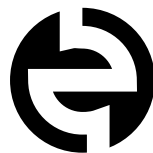

Where an application requires an actuation life of >500,000.
 We strongly recommend that your PCB be gold plated.
 For < 500,000 a graphite coating can be used.